

FAMSI © 2008: Zachary Nelson

Satellite Survey of El Zotz, Guatemala

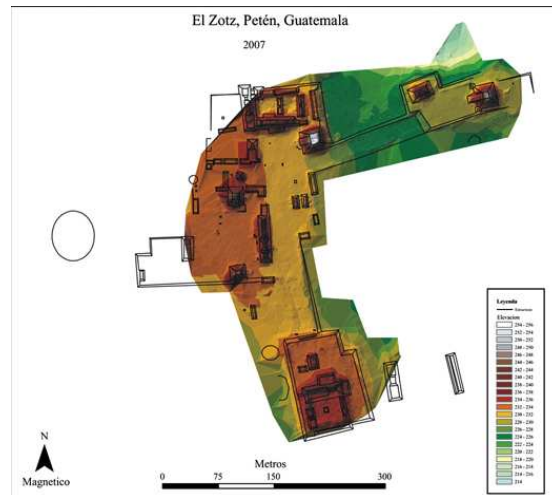

Research Year: 2007

Culture: Maya

Chronology: Pre-Classic through Terminal Classic

Location: Petén, Guatemala

Sites: El Zotz, El Diablo, Las Palmitas, El Palmar

Table of Contents

[Abstract](#)

[Resumen](#)

[Introduction](#)

[Objectives](#)

[Methods and Findings](#)

[El Zotz Mapping](#)

[Las Palmitas](#)

[El Diablo](#)

[El Palmar](#)

[Conclusions](#)

[Acknowledgments](#)

[List of Figures](#)

[Sources Cited](#)

Zachary Nelson
Brigham Young University
zn@byu.edu

Abstract

IKONOS satellite imagery is not a cure-all for effective canopy penetration in Petén, Guatemala. It failed to distinguish between sites and natural features at El Zotz, Guatemala. Various types of data manipulation failed to provide sufficient penetrating power. This suggests that micro-environmental factors may be at work, and a pan-Petén process is still in the future.

Ground survey of the El Zotz region included mapping at subsidiary sites. Las Palmitas (North Group) has a pyramid with a standing room complete with ancient and modern graffiti. El Diablo (West Group) was mapped. El Palmar, near a cival or residual lake, is configured in an “E-Group” pattern similar to astronomical features identified at Uaxactún.

Resumen

Las imágenes de satélite de tipo IKONOS todavía no sirven en todo el Petén para penetrar la selva. En El Zotz, las imágenes no pudieron distinguir entre edificios y selva aun con manipulación digital. Eso quiere decir que éxito puede ser un resultado de factores micro-ambiental y todavía no hemos logrado un sistema que siempre funciona.

Mapeo de pie en la región alrededor de El Zotz incluyó elaboración de mapas de sitios pequeños. Las Palmitas, o sea el grupo norte, tiene una pirámide con un cuarto abierto. Aquí hay grafitos modernas y antiguas. El Diablo, o sea el grupo oeste, también fue mapeado. El Palmar, ubicado cerca de un cival, fue construido conforma a un grupo E de Uaxactún para propósitos astronómicos.

Introduction

This project focused on a small ancient Maya center called El Zotz. This little-known settlement lies 23 km west of Tikal and flourished during the 6th/7th century despite being antagonistic to Tikal. Because little is known about this center and its environs, Drs. Stephen Houston and Hector Escobedo began investigating the site in 2006. It quickly became apparent that the tropical underbrush would hinder mapping, as it does elsewhere in the Petén.

El Zotz is located in the San Miguel la Palotada Biotope ([Figure 1](#)). It sits along a natural valley that connects Tikal westward to the rest of the Petén. This valley could have been used as a trade route between Tikal and El Peru or into the Lake Petén Itzá area. The site has not been the subject of formal archaeological projects, although archaeologists have known about it since the 1970s when it already was heavily looted. Previous archaeological work at the site includes limited mapping, a few test pits, and salvage work (Andrews 1986, Quintana 2001, Ruiz Aguilar 2004). It was hoped that IKONOS imagery of the region would advance the mapping of the site and its environs by

providing a vegetative signature that identifies ancient settlement through a disturbance in the ground vegetation.

IKONOS satellite imagery has been hyped as a means of distinguishing settlement from natural features under the tropical rainforest canopy of Guatemala (See *Nova ScienceNOW: Maya on San Bartolo survey*). Recently, Tom Sever, Dan Irwin, and William Saturno have provided evidence that tropical vegetation can serve as a proxy for settlement in identifying undiscovered sites near San Bartolo, Guatemala (e.g., Burkey 2006). Because the nature of such claims have profound implications for archaeological work in the Maya zone, this project sought to test their claims by using IKONOS imagery in conjunction with mapping at the site of El Zotz, Guatemala. Satellite imagery has been used for years in locating ancient settlements including in the Maya zone (e.g., Duller 1990, Ebert and Lyons 1980, Custer *et al.* 1986, Pope and Dahlin 1989, Sever 1990, 1998, 2000, Sever and Irwin 2003). A significant breakthrough in methodology would be a great boom to identifying settlements in unexplored regions, like El Zotz.



Figure 1. Regional Map of Area showing archaeological sites.

Objectives

This project has several objectives. First, there is a need to fill the lacuna on the archaeological map of the Petén. No comprehensive survey has been undertaken in the region around El Zotz. This region is under threat from the activities of local inhabitants looking for xate palms (*Chamaedorea* spp.) and other valuable portable resources including artifacts.

Second, this is an opportunity to test the effectiveness of IKONOS satellite imagery in predicting the locations of undiscovered sites. Satellite imagery in archaeology is not new; it has been used effectively to identify archaeologically important details on the landscape for years (e.g., Duller 1990, Ebert and Lyons 1980, Custer *et al.* 1986, Pope and Dahlin 1989, Sever 1990, 1998, 2000, Sever and Irwin 2003). However, it has not been very successful in the Maya region due to the tropical forest canopy that covers much of the region. Recent work by Tom Sever, Dan Irwin, and William Saturno may lead to a breakthrough in this regard. They have found that by using vegetation as a proxy for settlement, they can identify undiscovered sites near San Bartolo, Guatemala (e.g., Burkey 2006). This is a great opportunity to test their methods.

Finally, this project will aid in identifying ancient boundaries and determining how they were maintained over time. The Western Tikal earthworks lie between El Zotz and Tikal. This enigmatic ditch-like feature might be better understood via survey from the outside. While the proposed research will not be able to systematically survey the 23 km to Tikal, it will provide settlement information which will in future field seasons connect the El Zotz transect with Puleston's and Webster's transects on the western edge of Tikal. If the settlement patterns (architecture, artifacts, agricultural practices) change from an El Zotz pattern to a Tikal pattern, then we will have valuable information on boundaries and community ties.

Methods and Findings

GeoEye provided IKONOS imagery of the area around El Zotz ([Figure 2](#)). Their high-resolution image was taken on January 15, 2007 using their IKONOS-2 satellite. The photos were "standard geometrically corrected" with a nearest neighbor interpolation and consisted of four bands: Near-infrared (NIR), Red (R), Green (G), and Blue (B).

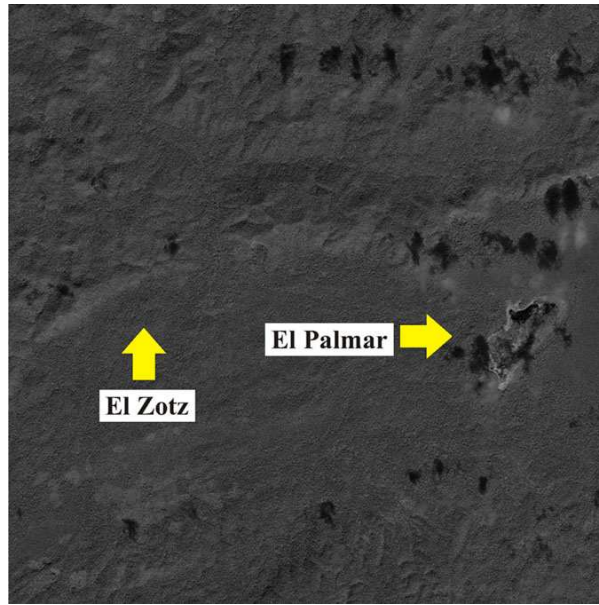

Figure 2. IKONOS Image of El Zotz Region.

William Saturno, while working at San Bartolo, Petén, found that structures could be distinguished from vegetation by slight discolorations in an untouched satellite image. A visual inspection of an El Zotz composite image created individually in ArcGIS 9, ENVI 4.2 and IDRISI Andres failed to distinguish between El Zotz and surrounding vegetation. The location of El Zotz is known from GPS coordinates, and its outline was superimposed on each image ([Figure 3](#)). Because a visual inspection failed to identify the site, other data manipulation occurred.

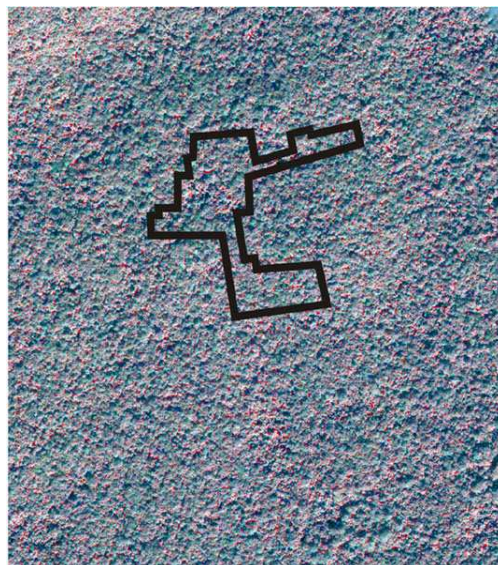

Figure 3. Color composite with El Zotz outline.

Tests were run on the IKONOS imagery using ENVI 4.2 and IDRISI Andes. Composite images were made primarily with NIR-R-B bands (instead of the more common R-G-B bands). This combination of bands is believed to provide better contrast with vegetation. Image processing included Brovey analysis, Principle Components Analysis, and NDVI. These analyses were chosen because they provide slightly different ways of computing differences, and have been used successfully elsewhere in the world to distinguish features upon a landscape.

The aim of the image processing is to correlate structures with vegetation colors. Slight changes in vegetation coloring is thought to be related with nutritional deficiencies in vegetation growing on structures. San Bartolo's imagery shows such a pattern in the satellite imagery.

Unfortunately, no correlation appeared. El Zotz remained indistinguishable on the images. Disturbed areas along the road toward the site, where clay deposits have necessitated wider road cuts, show up far more readily than areas with known settlement. In this region, there does not seem to be a direct relationship between IKONOS satellite imagery and settlement.

The only modest success came with vertical exaggeration. There is a slight tendency for sites with elevated platforms to appear in the satellite imagery as elevated areas when they are not located on hills (via the 3D surface view with vertical exaggeration function in ENVI 4.2). Although the hills also are exaggerated. This method does not work consistently.

In sum, the IKONOS imagery over El Zotz does not provide Superman's X-ray vision. Canopy still obscures millennia old structures from view. IKONOS does appear to work at San Bartolo, which suggests that other environmental factors are at work. Perhaps micro-environmental factors may be present in the San Bartolo region that enhance vegetative differences. If such factors can be identified, then this technology will be very useful for Maya studies.

In the meantime, surveys will still need to be conducted on the ground. Mapping at El Zotz and its subsidiary sites occurred from May 14, 2007 through May 29, 2007 at El Zotz, Guatemala. All sites were mapped using a Topcon Total Station GTS 4B with FC-4 data collector. Additional spatial information was gathered using multiple Garmin Rhino 530 GPS devices. Both data sets were brought together in ArcGIS 9. Field personnel included Stephen Houston, Ana Lucía Arroyave, Juan Carlos Meléndez, Cassandra Mesick, Zachary Nelson, Francisco Paz, and Fabiola Quiroa.

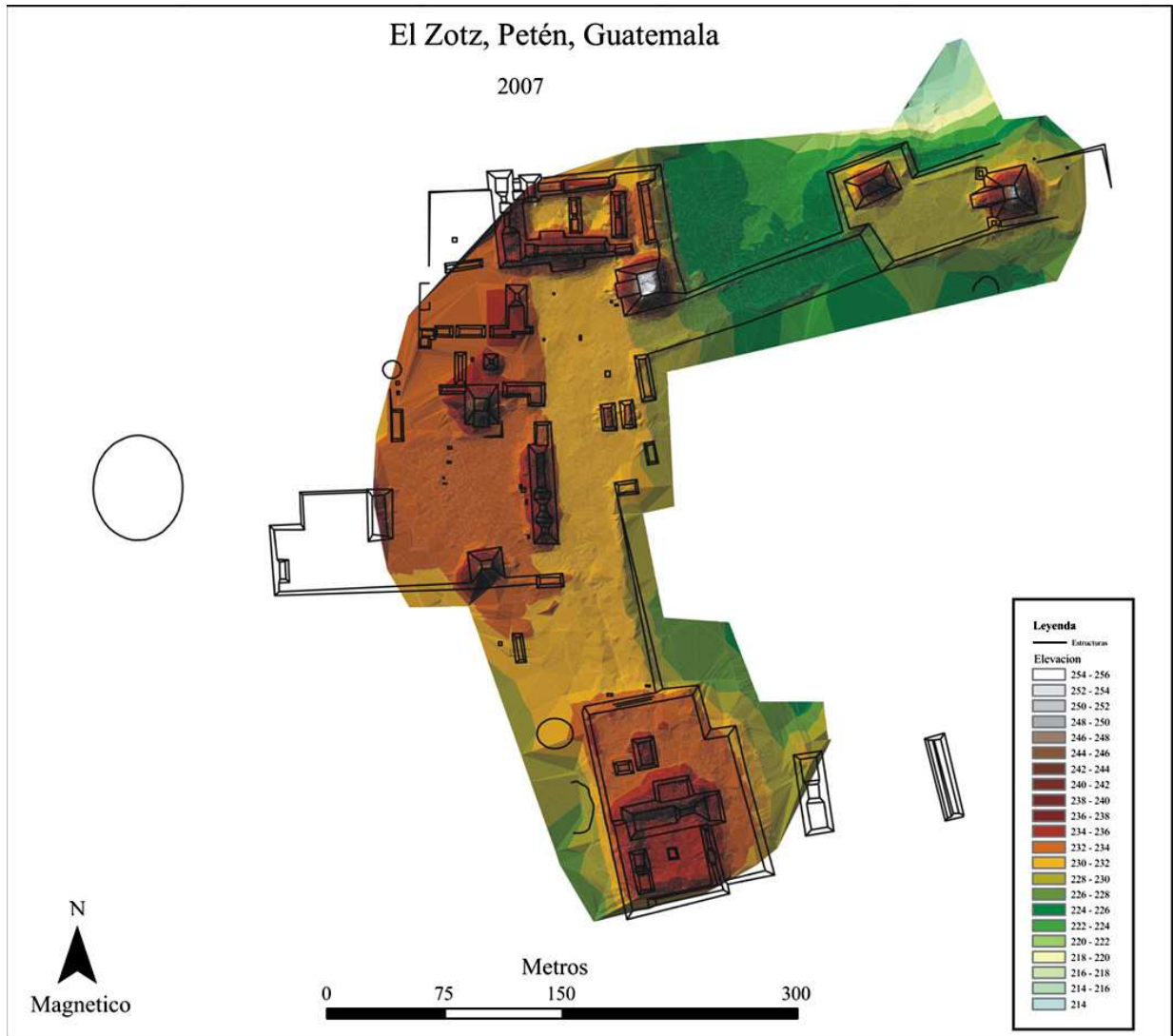
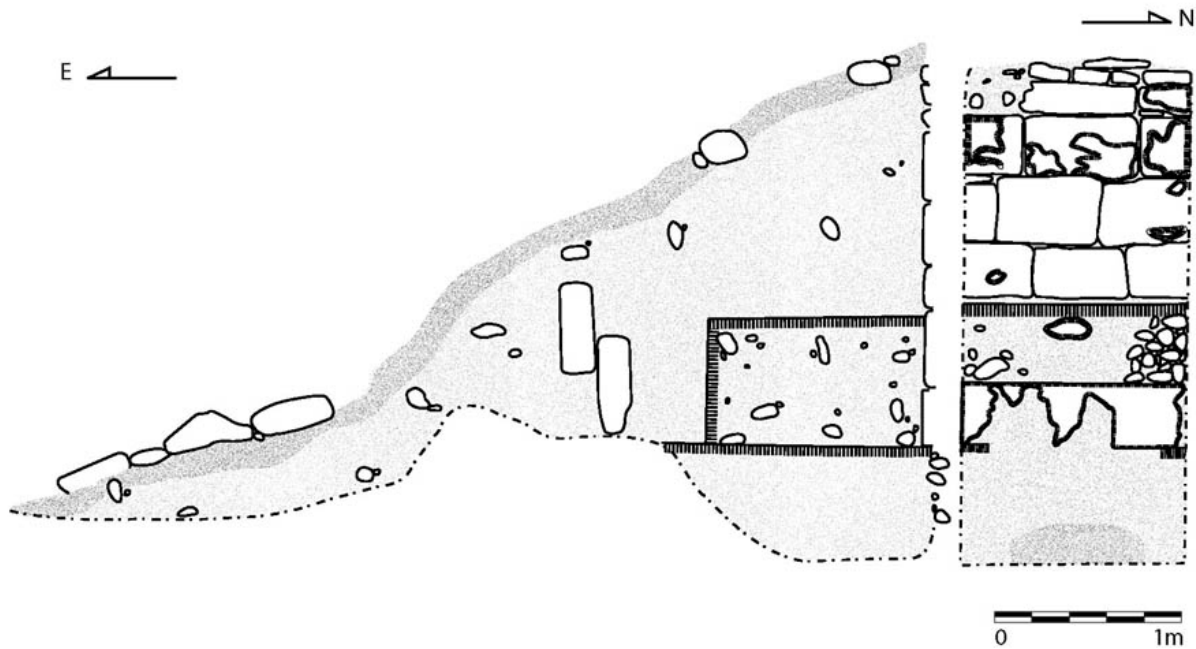

Figure 4. Map of El Zotz.

El Zotz Mapping

El Zotz is a small Maya center, about 0.75 km by 0.75 km ([Figure 4](#)). Its modern name results from its association with a nearby collapsed cenote or sink hole, from which thousands of bats emerge each night. Anciently, its rulers used a “split-sky” glyph, equivalent to the one used at Yaxchilán (Houston *et al.* 2006:11). Ceramics recovered from the numerous looter’s trenches show that El Zotz has a brief history. It flourished from circa CE 6th Century to early 7th Century. During this same time period, its nearest large neighbor, Tikal, was experiencing political weakness (Martin and Grube 2000:38-41). The hieroglyphic evidence from the region shows El Zotz allied with Tikal’s enemies including Calakmul and El Peru (Houston *et al.* 2006:11). It may be that El Zotz’s foundation related to the building of Tikal’s western earthwork (see Webster *et al.* 2004).

In 2006, most of the central plazas were mapped by essentially the same field team (Houston *et al.* 2006). This season, mapping continued along the southern side of the site into a large spatially discrete complex that might have housed elite members of ancient Maya society. Like other sectors of El Zotz, this area had been heavily looted in the past. Looter's tunnels penetrated many of the structures, leaving behind evidence of construction episodes amid piles of back-dirt. Several of these tunnels were drawn, to provide information about the construction of the group ([Figure 5](#)).



**Figure 5. Drawing of Looter's tunnel from El Zotz, Structure L9-4.
Drawing by Juan Carlos Meléndez and Ana Lucía Arroyave.
Digitized by Juan Carlos Meléndez.**

Las Palmitas (El Grupo Norte)

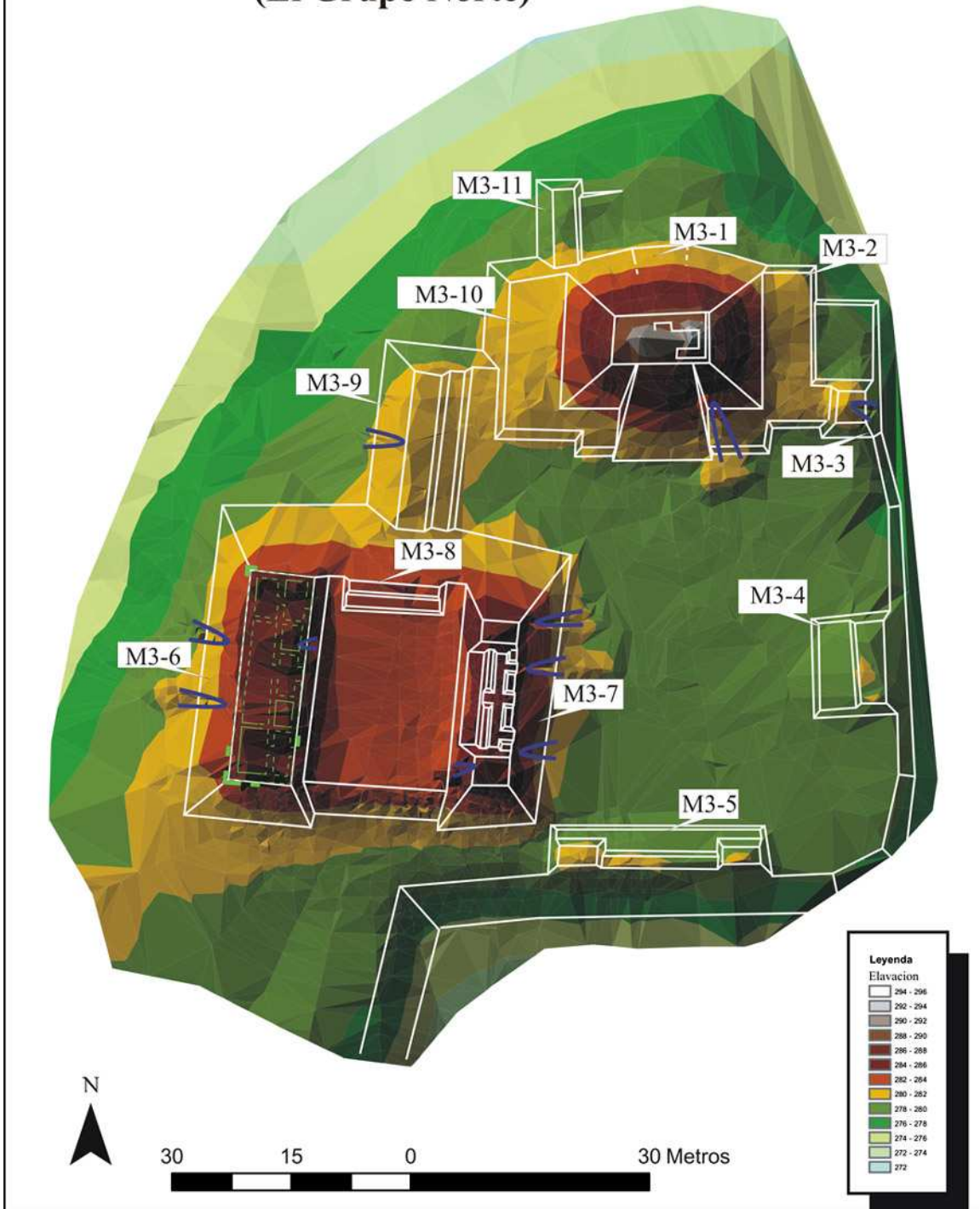

Figure 6. Map of Las Palmitas complex.

Las Palmitas

Las Palmitas is located on a medium sized hill due north of El Zotz ([Figure 6](#)). Its settlement consists of nine buildings with a possible mortuary temple. On the western side of the settlement is a possible “palace complex”. The main structures in this complex are oriented north-south across a plaza from each other. Each has three or more small rooms. Looter’s excavated into the structures from several positions, although there is no evidence that they removed much of consequence. The mortuary temple at the north of this site had open rooms on its summit. One open room still stands with ancient and modern graffiti etched into the walls. These were discovered and documented by Stephen Houston. The modern graffiti partially obscures some of the ancient graffiti with messages proclaiming “Xateros muertos de hambre” [Palm collectors dying of hunger] and other slogans. The ancient graffiti consists of figures drawn into the plaster on the walls. Incised were a pyramid, a god image, a parasol with man’s head in profile, and another pyramid structure ([Figure 7](#)). Due to the preservation of these images, it is possible that more drawing will be recovered in the future once the room is cleared of debris.



Figure 7. Graffiti from Las Palmitas pyramid (Lines artificially enhanced for clarity). Drawings by Stephen Houston: (A) Parasol and Face in profile. (B) Lines. (C) Pyramid. (D) God-image in profile.

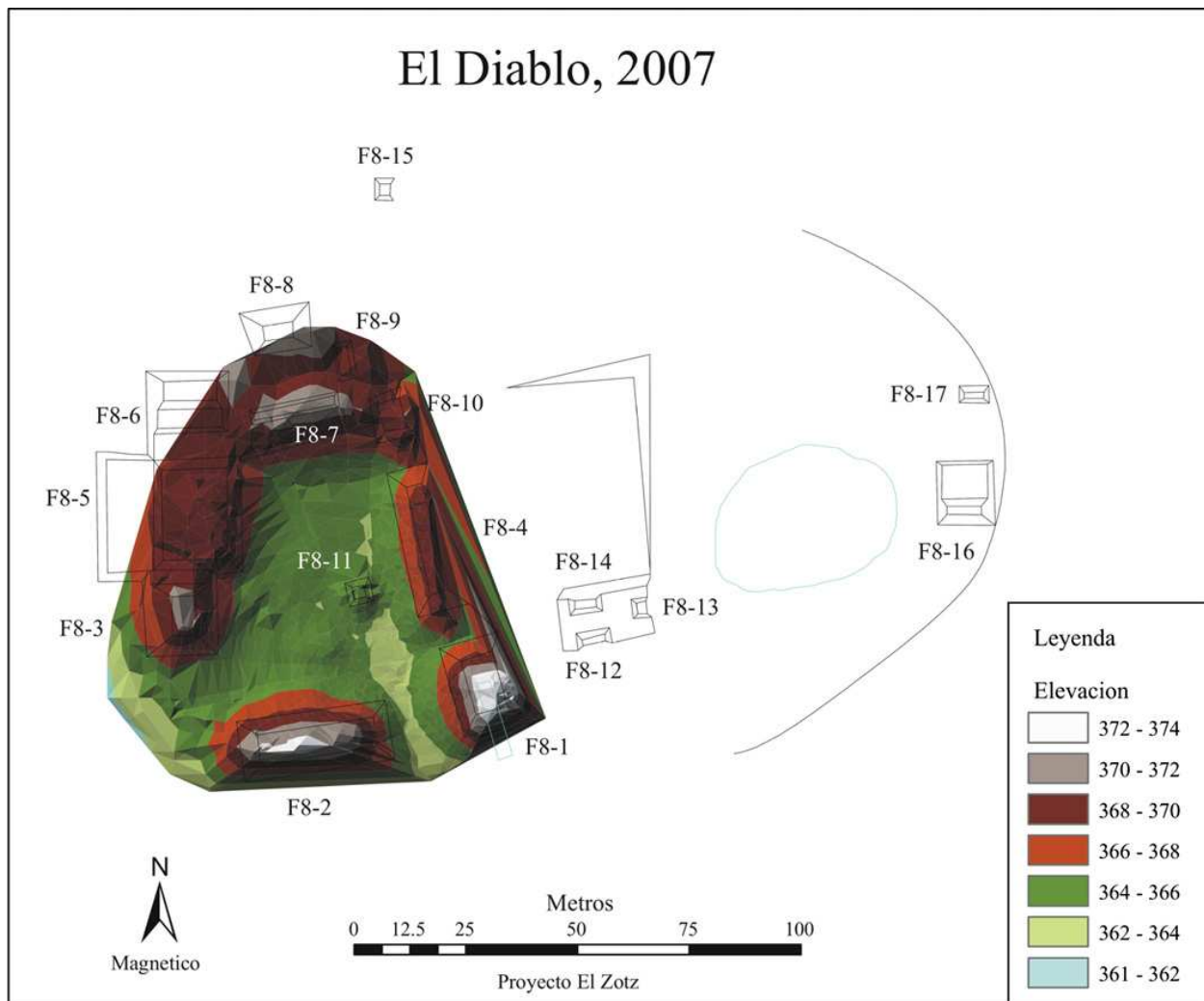
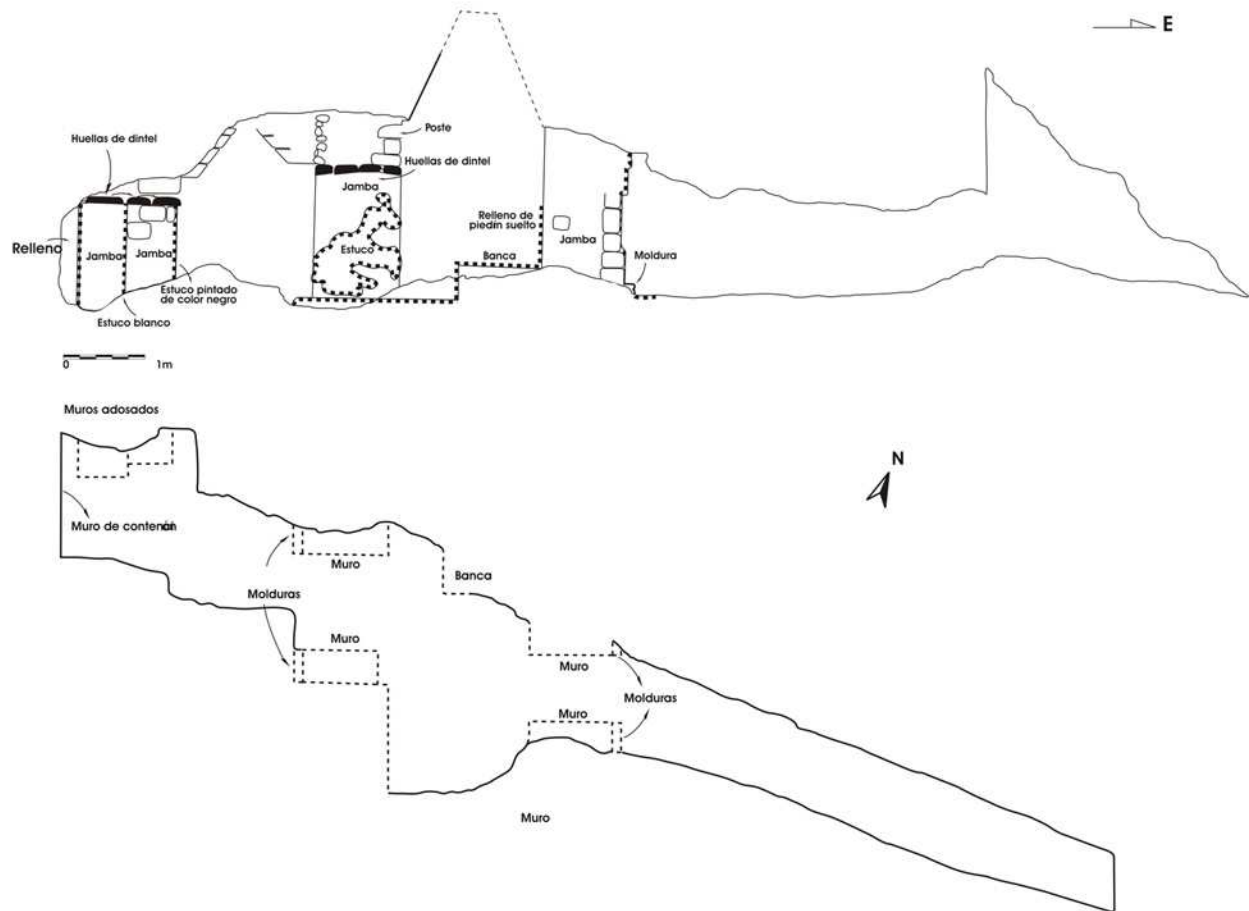

Figure 8. Map of El Diablo complex.

El Diablo

El Diablo is located on a high hill due west of El Zotz ([Figure 8](#)). Its settlement consists of 15 buildings including an elevated platform and possible mortuary temple. The height of the site is sufficient to see Tikal Temple IV from the summit of the mortuary temple. Looters also excavated the sides of the various structures in this complex. They put a three-meter-wide and ten-meter-deep trench through the temple. A secondary looter's tunnel into the southeastern side of the temple structure revealed a sequence of construction events ([Figure 9](#)).



**Figure 9. Profile of Looter's tunnel into El Diablo pyramid, Structure F8-1.
 Drawing by Juan Carlos Meléndez and Ana Lucía Arroyave.
 Digitized by Juan Carlos Meléndez.**

El Palmar

A reconnaissance team visited the site of El Palmar. This site is located along the side of a cival which is a permanent water source or residual lake bed. The site also has a possible mortuary temple and several elevated platforms. The orientation of some of the mounds forms an E-Group configuration such as found at Uaxactún ([Figure 10](#)). These kinds of configuration are thought to relate to astronomical and solstice events (Aimers and Rice 2006, Aveni and Hartung 1989, Chase and Chase 1995, Ricketson and Ricketson 1937, Ruppert 1940). Looters had also visited this site, and dug into the sides of many of the structures.

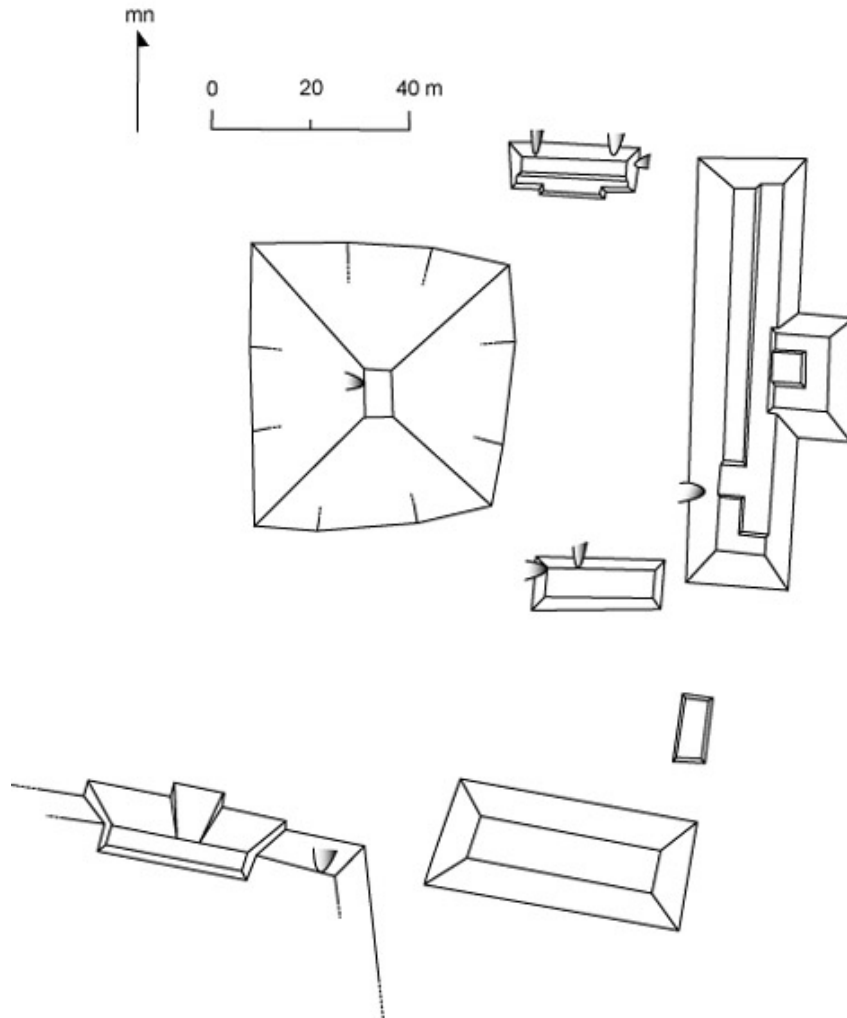

Figure 10. Sketch Map of El Palmar. Drawing by Stephen Houston.

Conclusions

Satellite photography is an important component of regional studies. It can provide important information about regional aspects of the landscape. In particular, the high resolution provided by IKONOS satellites has been used to distinguish between ancient settlements and surrounding vegetation. While this technique has been successfully used at San Bartolo, Petén, Guatemala, it has not been successful at El Zotz. Perhaps micro-environmental differences between the two centers are responsible for this discrepancy. In the meantime, survey continues on foot with Topcon Total Stations. Mapping at El Zotz and its environs have uncovered more of the site's extent and regional activities.

Acknowledgments

This work was possible through the support of the Departamento de Monumentos Prehispánicos, the Dirección General del Patrimonio Cultural y Natural de Guatemala and its Director General, Lic. Salvador López. Lilian Garrido coordinated logistical support. Gamaliel Jiménez provided secure transport to and from the site over treacherous roads. The Foundation for the Advancement of Mesoamerican Studies, Inc., (FAMSI) provided financial support via grant #07055. Dupee Family Professor of Social Science chair at Brown University, which Stephen Houston occupies, also provided significant financial aid. Special thanks are also due to our local Q'eqchi' helpers: Cristóbal Maquib, Jesús Coc, Eduardo Salam and Alfonso Maquib.

List of Figures

[Figure 1](#). Regional Map of Area showing archaeological sites.

[Figure 2](#). IKONOS Image of El Zotz Region.

[Figure 3](#). Color composite with El Zotz outline.

[Figure 4](#). Map of El Zotz.

[Figure 5](#). Drawing of Looter's tunnel from El Zotz, Structure L9-4. Drawing by Juan Carlos Meléndez and Ana Lucía Arroyave. Digitized by Juan Carlos Meléndez.

[Figure 6](#). Map of Las Palmitas complex.

[Figure 7](#). Graffiti from Las Palmitas pyramid (Lines artificially enhanced for clarity). Drawings by Stephen Houston: (A) Parasol and Face in profile. (B) Lines. (C) Pyramid. (D) God-image in profile.

[Figure 8](#). Map of El Diablo complex.

[Figure 9](#). Profile of Looter's tunnel into El Diablo pyramid, Structure F8-1. Drawing by Juan Carlos Meléndez and Ana Lucía Arroyave. Digitized by Juan Carlos Meléndez.

[Figure 10](#). Sketch Map of El Palmar. Drawing by Stephen Houston.

Sources Cited

Aimers, James J. and Prudence M. Rice

2006 Astronomy, Ritual, the Interpretation of Maya "E-Group" Architectural Assemblages. *Ancient Mesoamerica* 17:79-96.

Andrews, George F.

1986 Notes on "El Zotz": A Little-known Site in Petén, Guatemala. *Mexicon* VIII (6):123-125.

Aveni, Anthony and Horst Hartung

1989 Uaxactún, Guatemala, Group E and Similar Assemblages: An Archaeoastronomical Reconsideration. In *World Archaeoastronomy*, edited by Anthony F. Aveni, pp. 441-461. Cambridge University Press.

Burkey, Martin

2006 Newspaper article: Secrets of the Maya, published by the *Decatur Daily News* on February 28, 2006. Online version: <http://www.decaturdaily.com/decaturdaily/news/060228/satellite.shtml>.

Chase, Arlen F. and Diane Z. Chase

1995 External Impetus, Internal Synthesis, and Standardization: E-Group Assemblages and the Crystallization of Classic Maya Society in the Southern Lowlands. *Acta Mesoamerica* 8:87-101.

Custer, Jay F., Timothy Eveleigh, Vytautas Klemas, and Ian Wells

1986 Application of Landsat Data and Synoptic Remote Sensing to Predictive Models for Prehistoric Archaeological Sites: An Example from the Delaware Coastal Plain. *America Antiquity* 51:572-588.

Duller, Charles E.

1990 A Case for Archaeological Reconnaissance of the Cabo Catoche-Porvenir Region of the Northeastern Yucatan Peninsula. NASA TM-102248. Available at: http://ntrs.nasa.gov/archive/nasa/casi.ntrs.nasa.gov/19900013511_1990013511.pdf#search=%22Archaeological%20Reconnaissance%20of%20the%20Cabo%20Catoche-porvenir%20%22.

Ebert, James I. and Lyons Thomas R.

1980 Remote Sensing in Archaeology, Cultural Resources Treatment and Anthropology: The United States of America in 1979. *Aerial Archaeology* 5:1-19.

Houston, Stephen D., Héctor L. Escobedo and Juan Carlos Meléndez
2008 *Proyecto Arqueológico El Zotz: Informe No. 2, Temporada 2007*. Report submitted to the Instituto de Antropología e Historia, Guatemala. Available online at: http://www.brown.edu/Research/Houston_Research/pez/Houston-El_Zotz2008.pdf

Houston, Stephen D., Zachary Nelson, Héctor L. Escobedo, Juan Carlos Meléndez, Ana Lucía Arroyave, Fabiola Quiroa and Rafael Cambranes.
2006 *Levantamiento preliminar y actividades de registro en El Zotz, Biotopo San Miguel La Palotada, Petén*. Report submitted to the Instituto de Antropología e Historia, Guatemala. Available online at: http://www.brown.edu/Research/Houston_Research/pdf/Houston%20et%20al%202006%20-%20EI%20Zotz%20Informe.pdf.

Martin, Simon and Nikolai Grube
2000 *Chronicle of the Maya Kings and Queens: Deciphering the Dynasties of the Ancient Maya*. Thames and Hudson Ltd, London.

Pope, Kevin O. and Bruce H. Dahlin
1989 Ancient Maya Wetland Agriculture: New Insights from Ecological and Remote Sensing Research. *Journal of Field Archaeology* 16:87-106.

Quintana, Oscar and Wolfgang Wurster
2001 Ciudades Mayas del Noreste de Petén, Guatemala. *Materialien zur Allgemeinen und Vergleichenden Archaeologie Band* 59:1-194.

Ricketson, Oliver G. and Edith B. Ricketson
1937 *Uaxactún, Guatemala, Group E, 1926-1931. Part 1: The Excavations; Part II: The Artifacts*. Carnegie Institution of Washington, Publication No. 477. Carnegie Institution of Washington, Washington, DC.

Ruiz Aguilar, María Elena
2004 Materiales líticos asociados a una ofrenda del Clásico Temprano en el Zotz, Petén, Guatemala. *Los Investigadores de la Cultura Maya* 12 (1):81-97. Universidad Autónoma de Campeche, Campeche.

Ruppert, Karl
1940 A Special Assemblage of Maya Structures. In *The Maya and Their Neighbors: Essays on Middle American Anthropology and Archaeology*, edited by Ralph Linton, Harry Shapiro and George Vaillant, pp. 222-231. D. Appleton-Century, New York.

Sever, Thomas L.

1990 *Remote Sensing Applications in Archeological Research: Tracing Prehistoric Human Impact Upon the Environment*. Unpublished Ph.D. dissertation, University of Colorado, Boulder. University Microfilms, Ann Arbor, MI.

1998 Validating Prehistoric and Current Social Phenomena upon the Landscape of the Petén, Guatemala. In *People and Pixels: Linking Remote Sensing and Social Science*, pp. 145-163. National Academy Press, Washington, DC.

2000 Remote Sensing Methods. In *Science and Technology in Historic Preservation*, edited by Ray Williamson and Paul Nickens, pp. 21-51. Kluwer Academic/Plenum Publishers, New York.

Sever, Thomas L., and Daniel E. Irwin

2003 Landscape Archaeology: Remote-sensing Investigation of the Ancient Maya in the Petén Rainforest of Northern Guatemala. *Ancient Mesoamerica* 14:113-122.

Webster, David, Jay Silverstein, Timothy Murtha, Horacio Martinez, and Kirk Straight
2004 *The Tikal Earthworks Revisited*. Occasional Paper in Anthropology No. 28, Dept. of Anthropology, The Pennsylvania State University, University Park.